



EUROPEAN ARROW BOARD

11 Boeing Place, Mount Maunganui 3116 Ph: 07 575 0505

2/11 March Place, Belfast, Christchurch 8051 Ph: 03 323 7507

Email: admin@trafficsigns.co.nz www.trafficsigns.co.nz PO Box 4366, Mount Maunganui South 3149

FEATURES INCLUDE:

- ◆ Traffic Signs unique NZ designed and made **GEN2 Pivot AX Arrow System**© has less moving parts, comes ready to operate and complies with latest NZTA requirements for **NO** arrow downward operations
- ◆ 333mm Xenon Lights compliant to European standard EN12352-2006
- ◆ ASNZ engineered and certified for the following:
 1. Maximum vehicle speed of 110km/h including wind speed of 47km/h in retracted position
 2. Maximum vehicle speed of 50km/h including wind speed of 147km/h in extended position
- ◆ ASNZ engineered and certified, fully aluminium frame including one piece construction section to limit maintenance issues and increase lifespan
- ◆ Comes complete with electronic lifting system ready to wire up and operate
- ◆ In cab controller for all functions including real time display
- ◆ 24 Volt
- ◆ 12 month warranty T&C apply

(Patents pending)



**Combine the EAB with Traffic Signs NZ Ltd
UMAD - TL-2 Crash Attenuator for the
“Ultimate in Traffic Management Safety”**

Gen2 Pivot AX Arrow System© - 2015:

FEATURES:

Power Supply – 24 Volt

DETAS controller is used to control the main functions of the mother board

Emergency buttons with power supply motors has a disconnected relay for protection

TSNZ Pivot AX European Arrow Board will be delivered with frame and electronic lifting mechanism

It is up to the end user and installation engineer to ensure the installation is fit for purpose regarding travel, height, suitable mountings and wiring to the vehicle

TSNZ has developed a secondary control function and processors to run the twin Pivot AX Arrow system, which can also provide the option to over-write the Arrow replacement



MAINTENANCE

Monthly lubrication is required using “dry glide” or similar type product for the lifting tracks of the board.

This is not included as standard

INSTALLATION INSTRUCTIONS:

Please follow the installation instructions attached:

TSNZ request installing a voltage regulator as part of the Euro board, any board fitted without one will not be covered under warranty.

The system has been designed and engineered to AS/NZS 1170.2.2011 and AS/NZS 1664.2.1997

Installation as per the attached drawings of the underside foot print requires 4x M16 class 8.8 nuts & bolts/ per side at 400mm centres. The forced per bolt has been calculated at 36.2kN.

Based on the wind speeds discussed in calculation register No. 3002-09 acting on the Generation 2 Arrow Board. The resultant force per M16 mounting bolt has been calculated at 36.2kN. The structure that the Generation 2 Arrow Board is mounted to must be capable of withstanding the calculated resultant force of 36.2kN per bolt.

Please refer also to COPTTM and also note that a white up light with minimum output of 50 watts is to be attached to the deck to adequately illuminate the RG17.

For any further information refer to TSNZ Booklet or contact TSNZ direct.

Page 2:- Technical Sheet

Page 3 & 4: - Overall Dimension & Underside of Frame

Page 5 & 6: - Operating Instructions

Page 7: - Layout for LED 's and Xenon Lights

Page 8 & 9: - Wiring diagrams for Main and Secondary Mother Boards

TECHNICAL SHEET

European Arrow Board



FEATURES:		
ARROW LIGHT devices		Basic 200/201/206, 12-24V EN12352 L8H (steady light)
Flash light devices		Basic 302, 12-24V EN12352 L9M (flashing)
Arrow signal sliding		Automatic - motorized
Arrow panel lifting		Automatic – motorized
External lower bar		Optional: 8 lamps bar
Light / motor control	Remote multi-function controller available	With 15 meters of wire, IP66 connector
		Wireless controller + receiver
Visual information	Remote controller only	Arrow panel position
		Lift engine monitoring
	Light trailer and remote controller	Battery tester
		Lamp failure monitoring
Protections	Remote controller only	Light / motor key lock system
	Light trailer only	Up / down limit switch
	Light trailer and remote controller	Emergency buttons with power supply motors disconnect relays
Power supply		24 Volt
ARROW LIGHT consumption @12,5V	Basic200/201	120 Ah / day
	Basic202/203/206	155 Ah / day
Overall dimensions	H x W x D	310 x 390 x 130 mm
Weight		300 Kg
Operating temperature		-10...+55° C
Lifter engine (MOT2) consumption*		I nom = 20A, I peak=75A
Arrow engine (MOT1) consumption*		I nom = 2A, I peak=3,5A
*in order to avoid serious damages of the system, please respect the suggested engine features.		
Power supply		24 Volt
ARROW LIGHT consumption @12,5V	Basic200/201	120 Ah / day
	Basic202/203/206	155 Ah / day
Overall dimensions	H x W x D	310 x 390 x 130 mm
Weight		300 Kg
Operating temperature		-10...+55° C
Lifter engine (MOT2) consumption*		I nom = 20A, I peak=75A
Arrow engine (MOT1) consumption*		I nom = 2A, I peak=3,5A
*in order to avoid serious damages of the system, please respect the suggested engine features.		

NO SURFACE PROTECTION REQUIRED

SERIALS 5015/1
5015/2
5015/3
5015/4

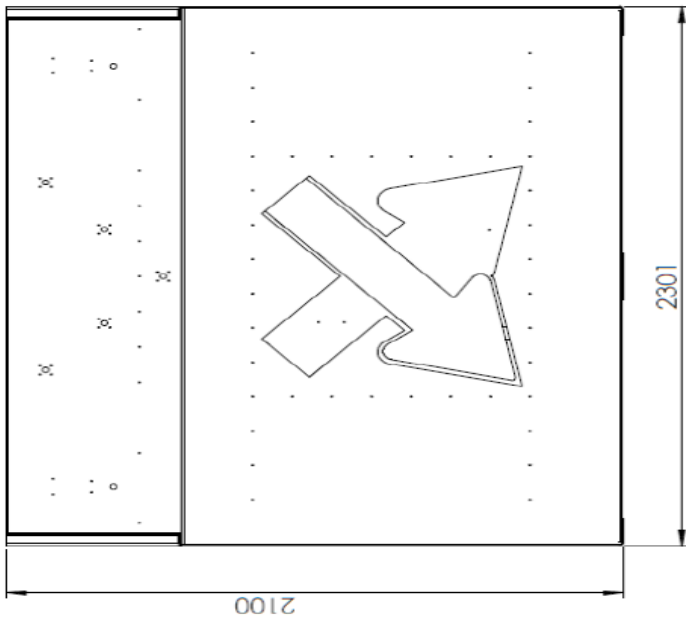

ARROW BOARD IN RETRACTED POSITION

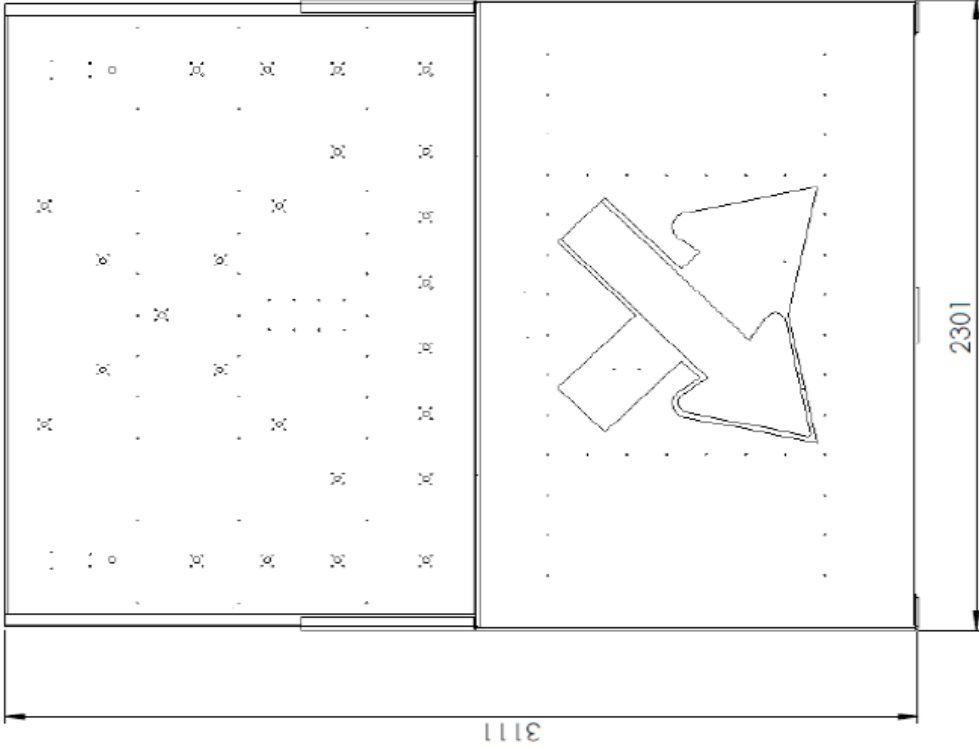

ARROW BOARD IN EXTENDED POSITION

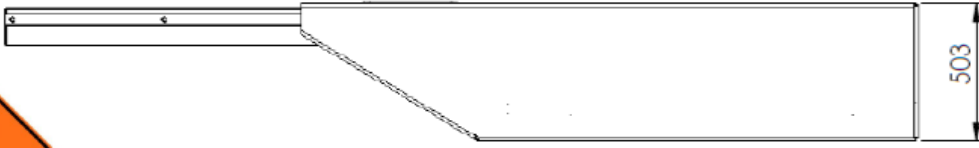

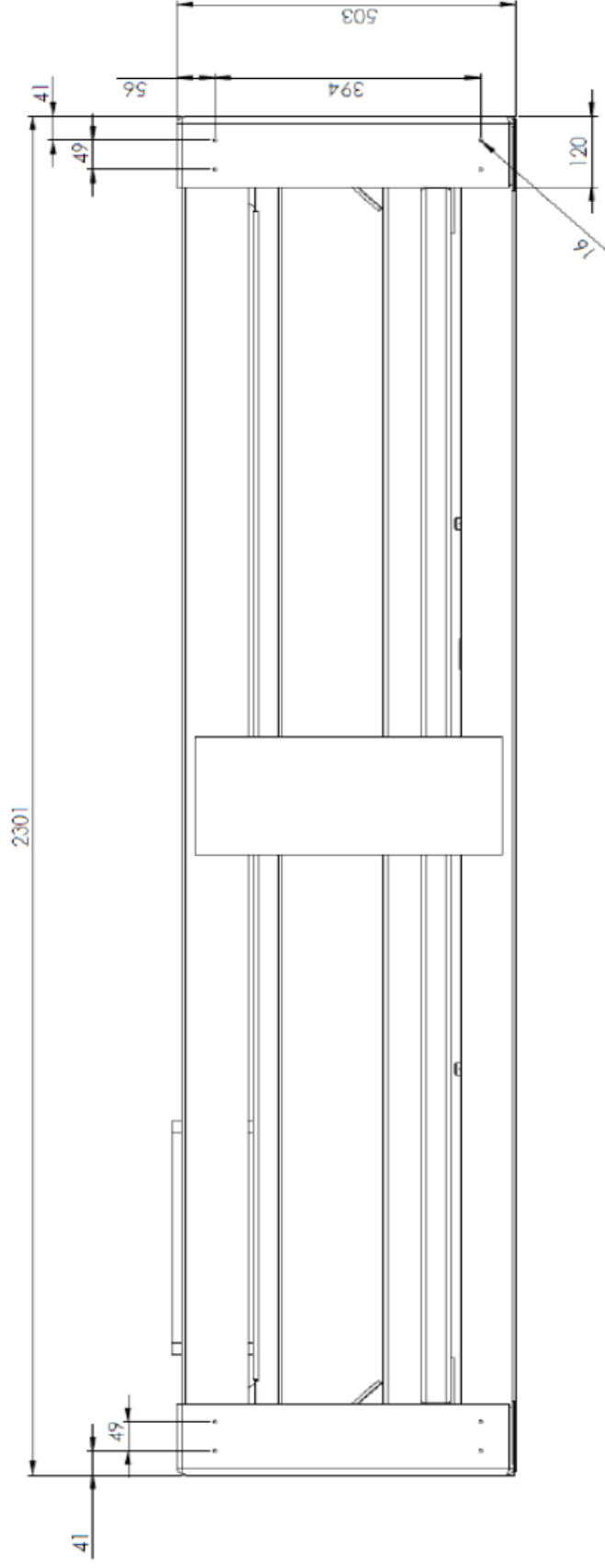

VIEW OF UNDERSIDE
FOOTPRINT



INSTRUCTIONS - EUROPEAN ARROW BOARD

11 Boeing Place, Mount Maunganui 3116 Ph: 07 575 0505
2/11 March Place, Belfast, Christchurch 8051 Ph: 03 323 7507

Email: admin@trafficsigns.co.nz www.trafficsigns.co.nz PO Box 4366, Mount Maunganui South 3149

Before the remote will work you must make sure the Emergency Control Button



Picture 1

Remote Control

Control Functions:

1. Emergency Butt
2. Battery Tester
3. Arrow Light control / check
4. Lamp Failure
5. Motor Panel control / check
6. External Arrow Bar check
7. Key On

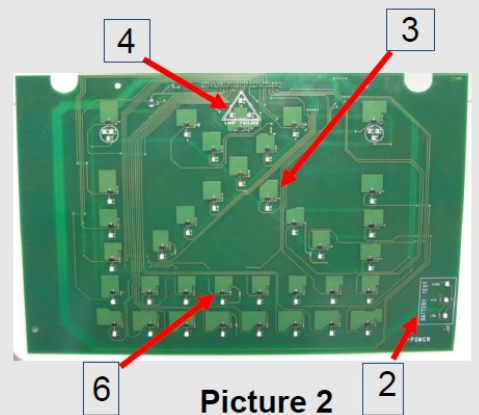

Picture 2
Circuit Board

To Lift Arrow Panel:



Push "Key On" Button (7) , light will come on and Down Button (5) light will come on, indicating the panel is down



Push Up Button (5) once and Panel will rise until it is in the upright position



Push Down Button (5) to return panel to the original starting position

Arrow Light Control:



Push "Key On" Button (7) again



Select the Arrow (3) you require to be lit up

Checks: When Unit is turned on check:

- **Failed Lamp** [4] - Red light will appear when one of the 25 lights fail
- **Battery Charge Level** [2] -
Green - Battery Full
Yellow - Battery 50% charged
Red - Battery Flat
- **KEY ON** - In order to avoid any involuntary action, pull out Emergency button [1] and press KEY ON [7] to activate the other functions on the controller

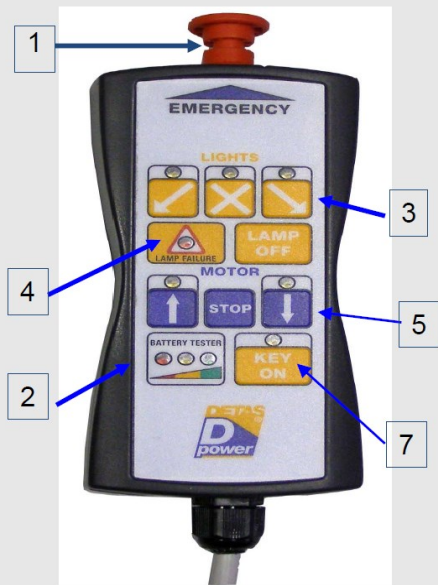

Picture 1
Remote Control

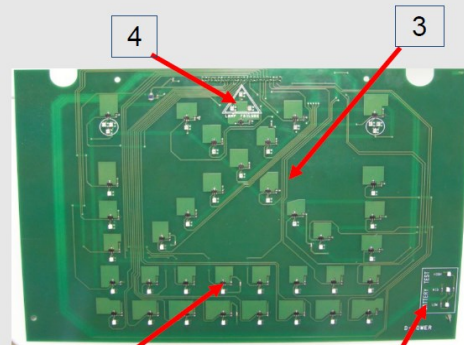

Picture 2
Circuit Board

SECONDARY - REMOTE CONTROL - RG17/34 OVERRIDE

- The override controller is used when the arrow board is in the standard "X" position, however you require the RG17/34 Blue/White arrow to show either left or right and not the standard "no arrow" function.

To select this function:

- Using the standard primary AX Pivot controller, select the X function that will have no downward arrow.
- Using the secondary controller, select the arrow option left or right.
- When completed, return the secondary controller to the X position and resume normal operations with the primary controller.



WARNING

PLEASE CONNECT THE DEVICE FOLLOWING
THE LAYOUT SHOWN BELOW

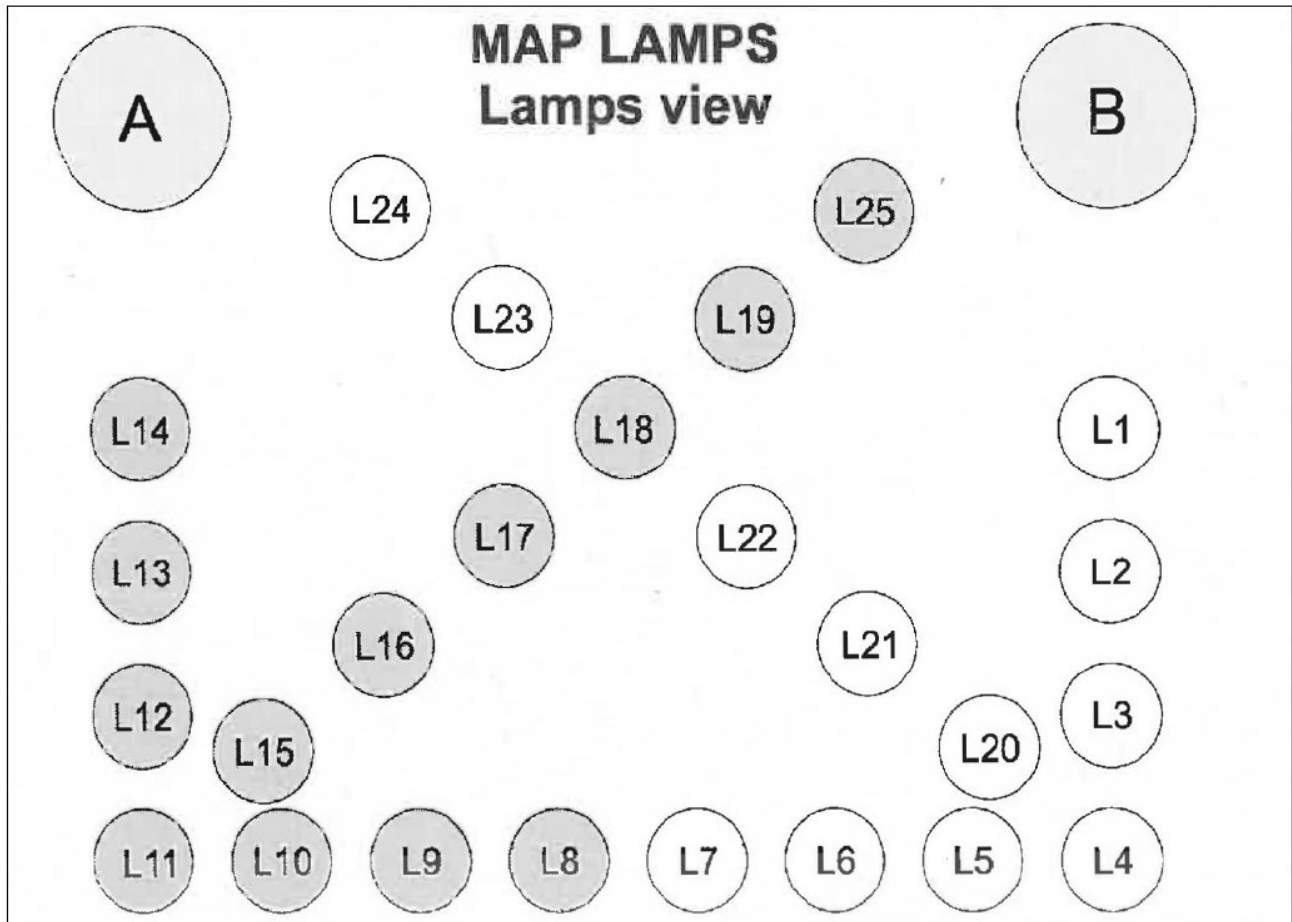

Device	Wire Section
Power Supply	2 x 6 mmq
L1 ... L25	2 x 1 mmq
A, B xenon	3 x 1,5 mmq
A, B Led	2 x 1 mmq



**CONNECTION DIAGRAM
(V.08)**

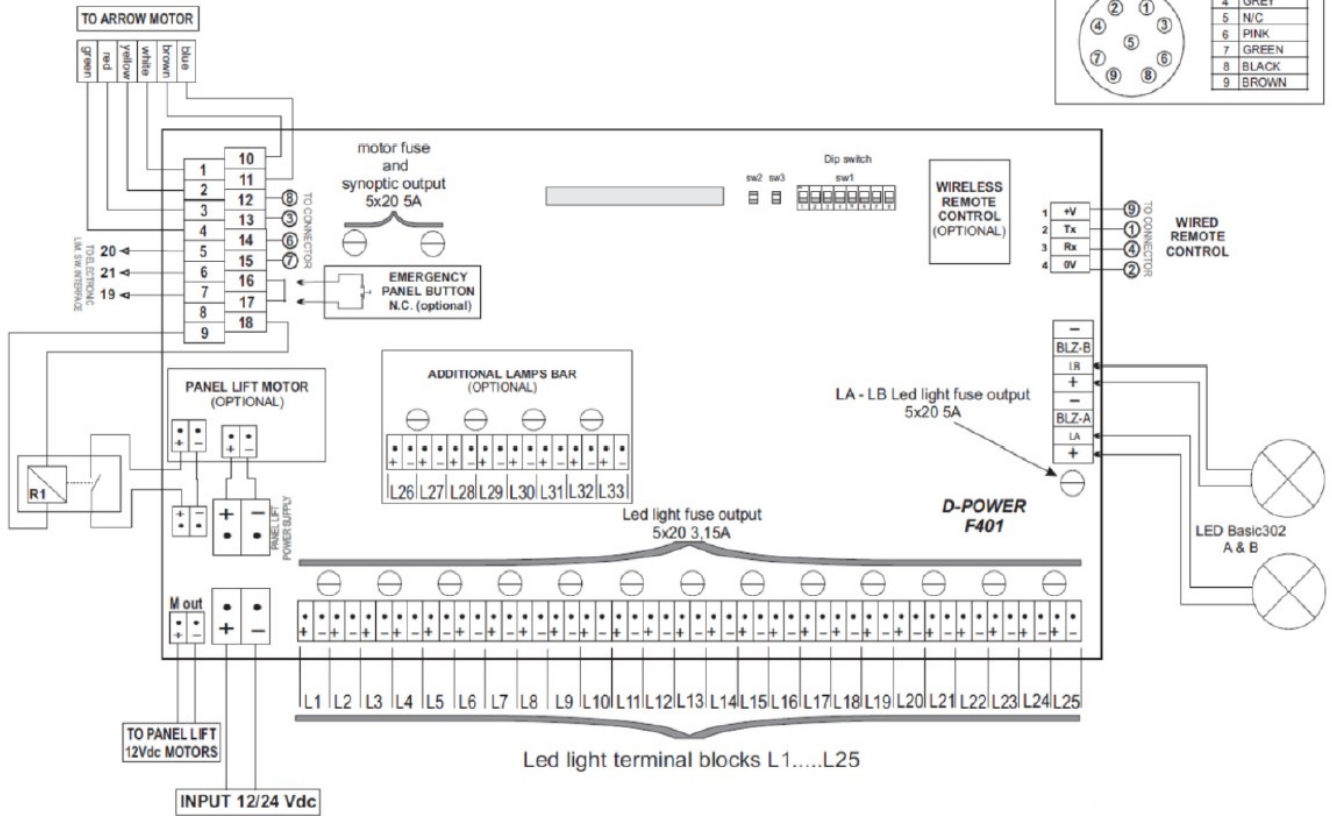

WIRED REMOTE CONTR. PANEL CONNECTOR (SOLDER VIEW)

1	YELLOW
2	WHITE
3	BLACK
4	GREY
5	N/C
6	PINK
7	GREEN
8	BLACK
9	BROWN

CONNECTION DIAGRAM—SECONDARY MOTHER BOARD

PLEASE CONNECT THE DEVICE FOLLOWING THE LAYOUT

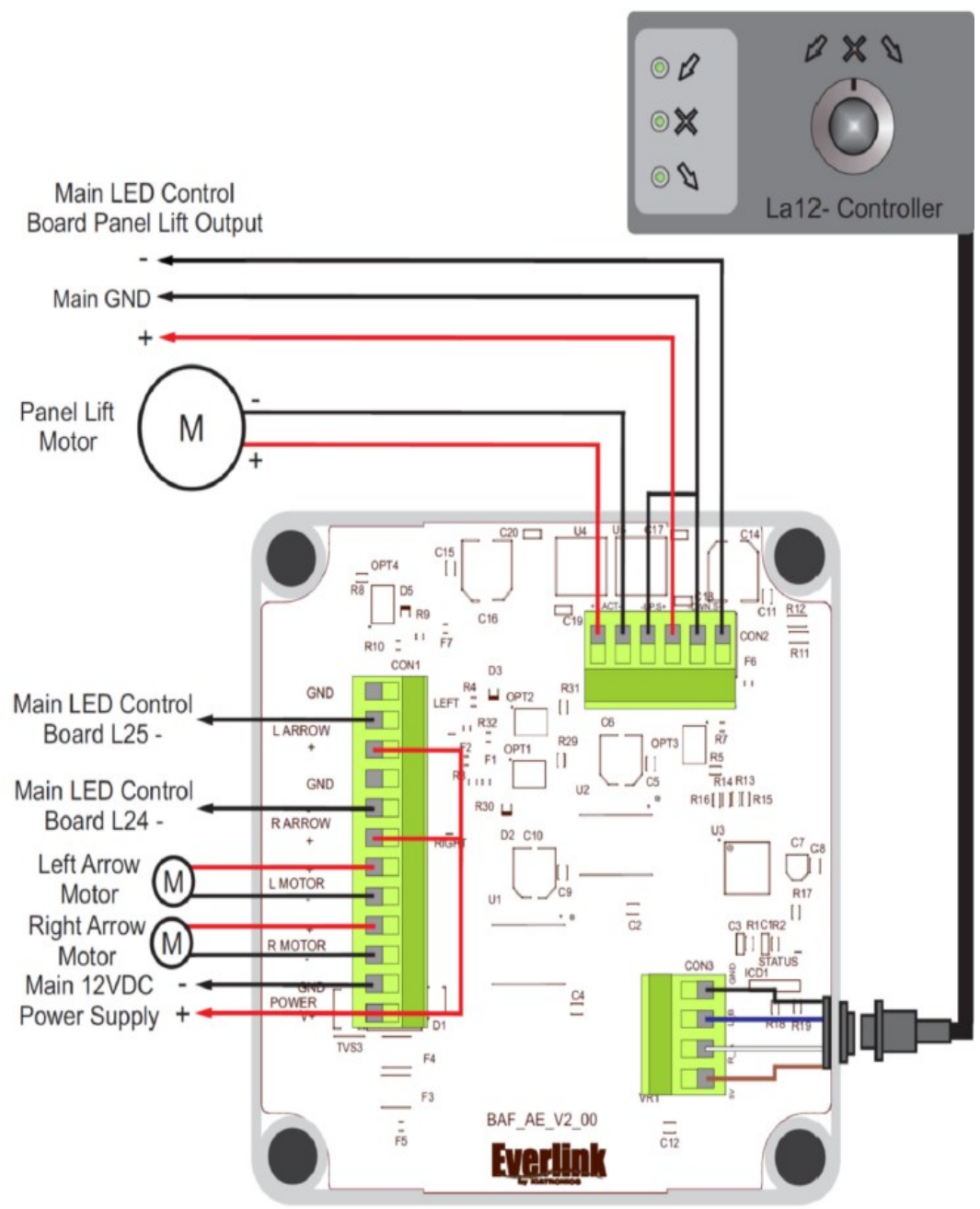

FOR TECHNICAL SUPPORT PLEASE CONTACT OUR ELECTRONICS TEAM

SERVICE PLANNER

M: 027 365 4452

E: service@trafficsigns.co.nz

QUALITY TRAFFIC SIGNS & ACCESSORIES AT COMPETITIVE PRICES

CONTACT US NOW FOR A QUOTATION

Visit our website www.trafficsigns.co.nz

